

# Product Guide 2009

*Manufacturers*

*of Quality*

*Architectural*

*Fiberglass*

*Products*



**FIBERGLASS  
SPECIALTIES  
INCORPORATED**

[www.fsiweb.com](http://www.fsiweb.com)

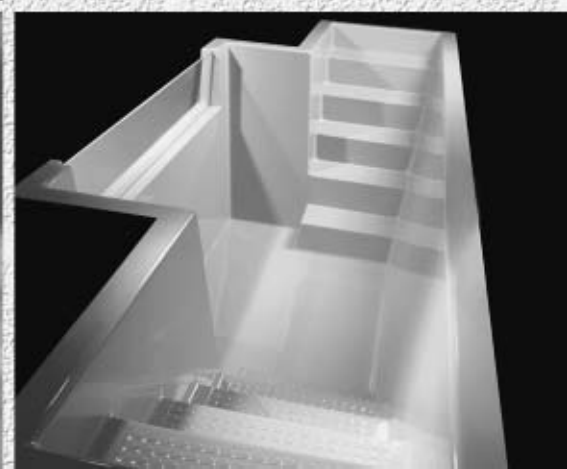

# **Table of Contents**

Steeple.....	3-10
Steeple & Cupola Accessories .....	11
Cupola .....	12-14
Lighthouse .....	15
Domes.....	16
Finials.....	17
Steeple & Cupola Installation Guidelines.....	18-19
Baptistries .....	20-24
Baptistry Accessories.....	24-25
Baptistry Installation Guidelines .....	24
Baptistry Heaters.....	26-27
Optional Items .....	26
Wall & Roof Crosses .....	28

## **About the Company...**

Founded in 1963, Fiberglass Specialties was one of the first manufacturers of fiberglass church baptistries, steeples, and wall crosses. Today we are the market leader, with the largest line of products in the industry. Our strong desire to improve our products and better serve our customers are the driving forces behind our constant innovation.

Fiberglass Specialties is a family owned business, now in its second generation. Owner and President Rocky Hall takes a hands-on approach not unlike that of his father, Howard Hall, who began the company over forty years ago.

We invite you to visit our 65,000 square foot manufacturing and office facility and see for yourself why Fiberglass Specialties is a name you can trust.

## **Free Design Service**

Fiberglass Specialties is pleased to offer a free design service to help visualize the right architectural choice for your building. Just send us a photo along with the height and width of the building. Our design engineers will create a CAD (Computer Aided Design) drawing of your facility with your selections of steeples imposed on the building. The drawings are 8-1/2" x 11", but after you choose a style, we'll be happy to reproduce a large print, suitable for mounting. It's a great way to attract donations!

**RULE OF THUMB**—Architects generally select a steeple that is about the same height as the distance from the ground to the peak of the roof of the building.

**NOTE:** All measurements, weights, and drawings shown in the catalog are rounded off and approximate.

# ***Steeple & Cupola Elements***

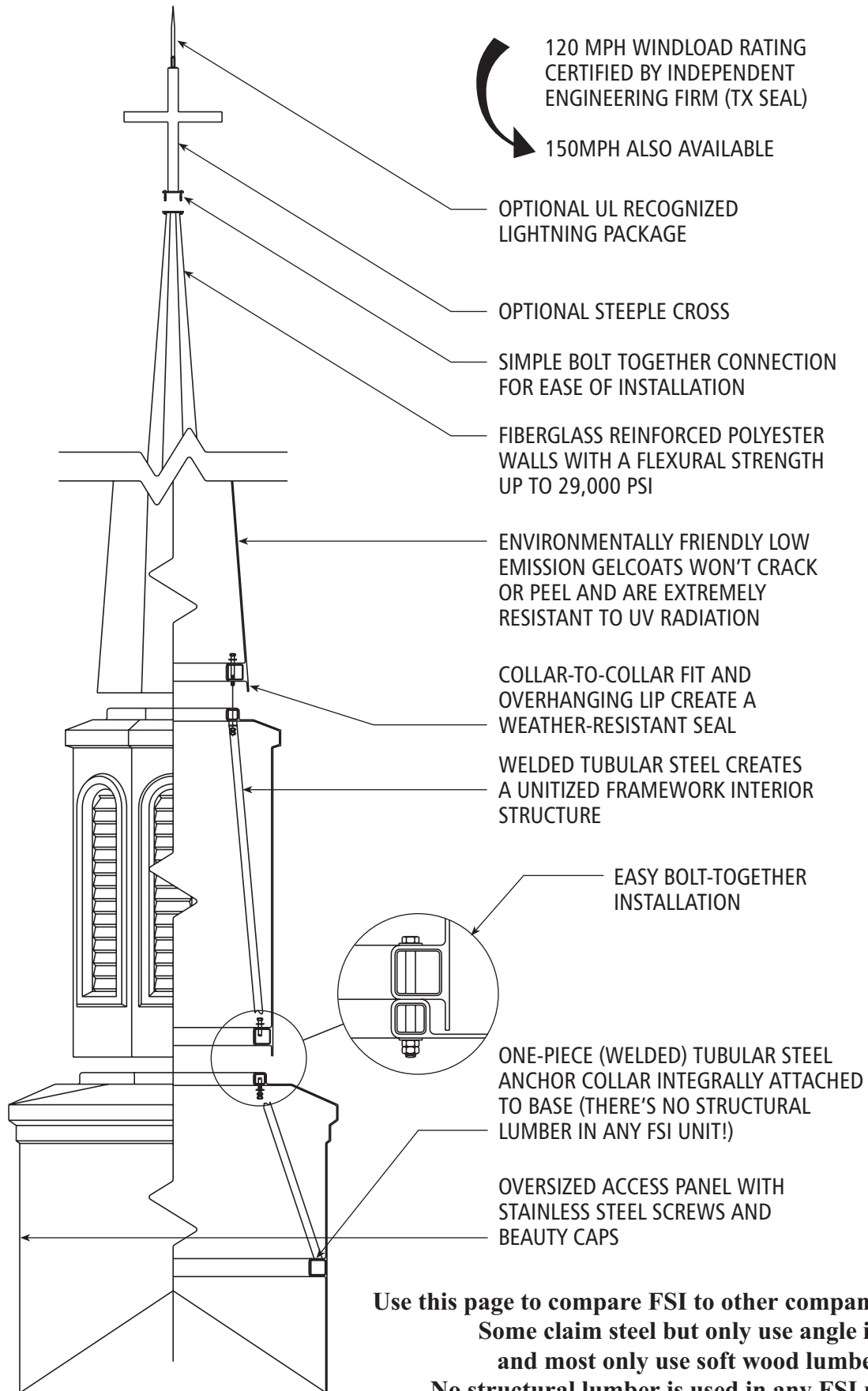

**Use this page to compare FSI to other companies' products.  
Some claim steel but only use angle iron  
and most only use soft wood lumber.  
No structural lumber is used in any FSI product.**

# Complete Cupola Units

All prices are FOB Henderson, Texas  
Please call for freight rates

## Cupola #CU1104

Height: 3'6"  
Base: 3'0"  
75 lbs

One piece unit

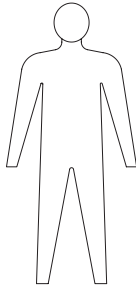
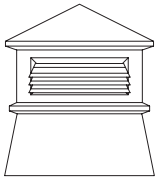

Vented louvers

## Cupola #CU1156

Height: 5'6"  
Base: 3'0"  
150 lbs

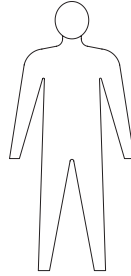
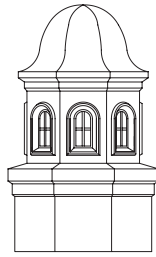

Vented louvers  
Krinkglas windows

## Cupola #CU1162

Height: 5'6"  
Base: 3'0"  
150 lbs

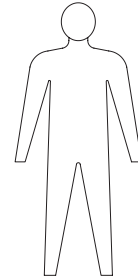

Vented louvers  
Krinkglas windows

## Cupola #CU1170

Height: 7'0"  
Base: 3'0"  
225 lbs

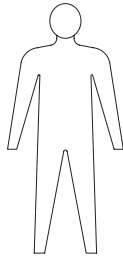

False louvers (square top)  
Vented louvers (square top)  
Krinkglas windows (square top)

## Cupola #CU1170H

Height: 7'0"  
Base: 3'0"  
225 lbs

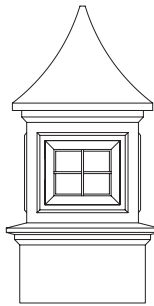

False louvers (square top)  
Vented louvers (square top)  
Krinkglas windows (square top)

## Cupola #CU1103

Height: 8'3"  
Base: 3'8"  
325 lbs

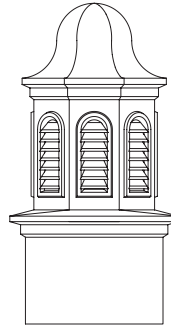

False louvers (round top)  
Vented louvers (round top)  
Krinkglas windows (round top)

## Cupola #CU1103S

Height: 8'3"  
Base: 3'8"  
325 lbs

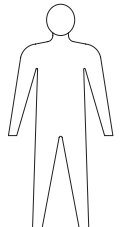
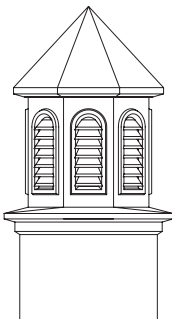

False louvers (round top)  
Vented louvers (round top)  
Krinkglas windows (round top)

## Cupola #CU1105

Height: 9'0"  
Base: 4'0"  
350 lbs  
One piece unit

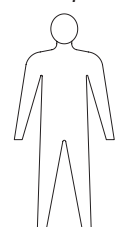

False louvers (round top)  
Vented louvers (round top)  
Krinkglas windows (round top)

## Cupola #CU1190

Height: 9'0"  
Base: 3'8"  
350 lbs

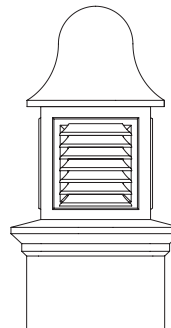

False louvers (square top)  
Vented louvers (square top)  
Krinkglas windows (square top)

# Complete Cupola Units

All prices are FOB Henderson, Texas  
Please call for freight rates

## Cupola #CU1190H

Height: 9'0"  
Base: 3'8"  
350 lbs

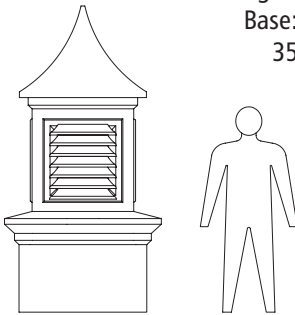

False louvers (square top)  
Vented louvers (square top)  
Krinklglas windows (square top)

## Cupola #CU1100

Height: 10'9"  
Base: 4'6"  
525 lbs

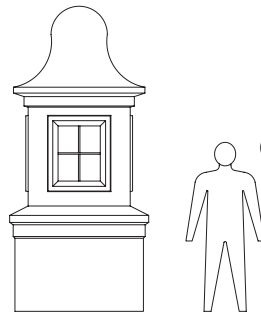

Dome #802  
Cupola #802

False louvers (square top)  
Vented louvers (square top)  
Krinklglas windows (square top)  
Round top also available

## Cupola #CU1100H

Height: 10'9"  
Base: 4'6"  
525 lbs

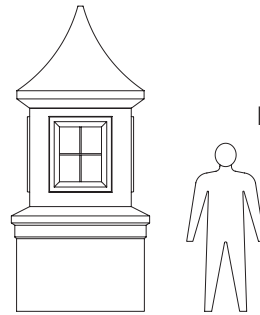

Dome #802H  
Cupola #802

False louvers (square top)  
Vented louvers (square top)  
Krinklglas windows (square top)  
Round top also available

## Cupola #CU1107

Height: 14'6"  
Base: 5'0"  
600 lbs

Dome #603H  
Cupola #603  
Base Cupola #604

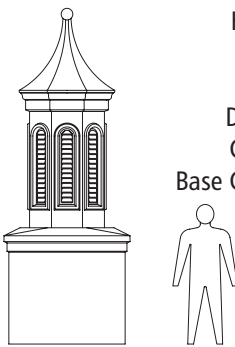

False louvers (round top)  
Vented louvers (round top)  
Krinklglas windows (round top)  
Square top also available

## Cupola #CU1102

Height: 13'8"  
Base: 6'0"  
700 lbs

Dome/Cupola #605A  
Base Cupola #607

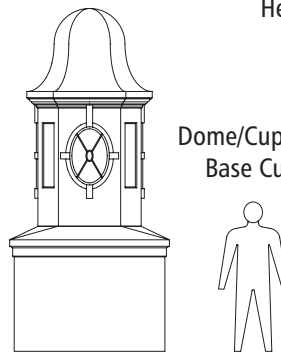

Vented louvers (oval only)  
Krinklglas windows (oval only)

## Cupola #CU1165

Height: 10'9"  
Base: 4'0"  
430 lbs

Cupola #1156  
Cupola #1105

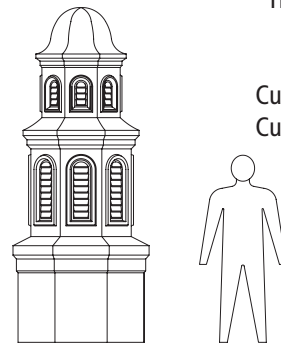

False louvers  
Vented louvers (bottom unit only)  
Krinklglas windows (bottom unit only)

## Cupola #CU1101

Height: 14'6"  
Base: 7'0"  
1025 lbs

Dome #701  
Cupola #701  
Base Cupola #702



False louvers (round top)  
Vented louvers (round top)  
Krinklglas windows (round top)

## Cupola #CU1101H

Height: 14'6"  
Base: 7'0"  
1025 lbs

Dome #701H  
Cupola #701  
Base Cupola #702



False louvers (round top)  
Vented louvers (round top)  
Krinklglas windows (round top)

## NEW! Cupola #CU1101RD

Height: 14'6"  
Base: 7'0"  
1025 lbs

Dome #701RD  
Cupola #701  
Base Cupola #702

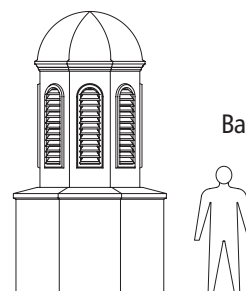

False louvers (round top)  
Vented louvers (round top)  
Krinklglas windows (round top)

# Complete Cupola Units

All prices are FOB Henderson, Texas  
Please call for freight rates

## Cupola #CU1400

Height: 18'0"  
Base: 8'0"  
1550 lbs

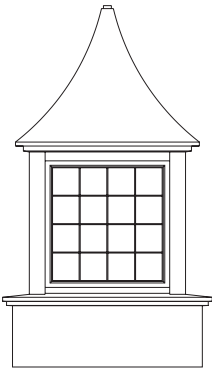

One piece unit



Vented louvers (square top)  
Krinkglas windows (square top)

## Cupola #CU1109H

Height: 22'0"  
Base: 10'0"  
2150 lbs

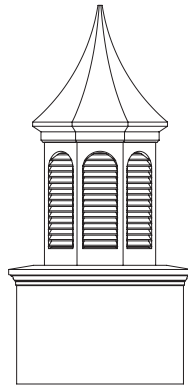

Dome #1050  
Cupola #1050  
Base Cupola #705

Order CU1109  
for "Dome top"  
as shown  
on CU1108



Vented louvers (round top)  
Krinkglas windows (round top)

## Cupola #CU1108

Height: 21'6"  
Base: 8'9"  
2100 lbs

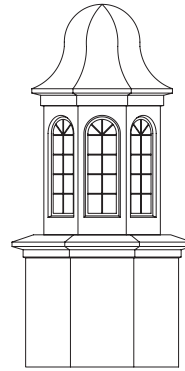

Dome #1050  
Cupola #1050  
Base Cupola #1075

Order CU1108H  
for "Hat style"  
as shown  
on CU1109



Vented louvers (round top)  
Krinkglas windows (round top)

## NEW! Cupola #CU1108CB

Height: 21'6"  
Base: 10'0"  
2100 lbs

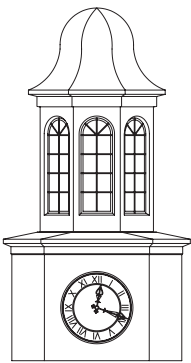

Dome #1050  
Cupola #1050  
Base Cupola #1076



Vented louvers (round top)  
Krinkglas windows (round top)

## Cupola #CU1127

Height: 11'8"  
Base: 6'0"  
900 lbs

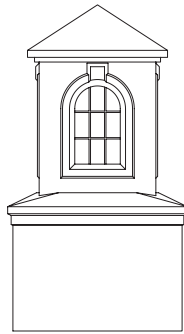

Cupola #405  
Base #607



Vented louvers  
Krinkglas windows

## Cupola #CU1200

Height: 21'0"  
Base: 10'0"  
2100 lbs

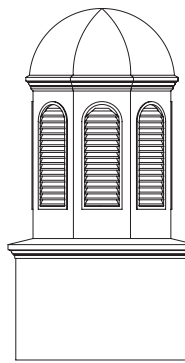

Dome/Cupola #1250  
Base Cupola #705



Vented louvers (round top)  
Krinkglas windows (round top)

## Cupola #CU1106H

Height: 25'6"  
Base: 10'0"  
2200 lbs

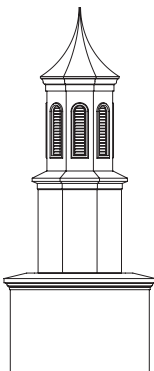

Dome #701H  
Cupola #701  
Cupola #700  
Base Cupola #705



False louvers (round top)  
Vented louvers (round top)  
Krinkglas windows (round top)

## NEW! Cupola #CU1106CB

Height: 25'6"  
Base: 10'0"  
2200 lbs

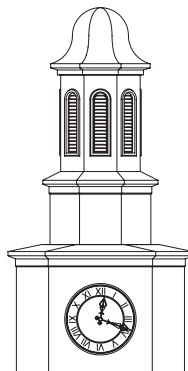

Dome #701  
Cupola #701  
Cupola #700  
Base Cupola #1076



False louvers (round top)  
Vented louvers (round top)  
Krinkglas windows (round top)

## Cupola #CU1300

Height: 28'0"  
Base: 10'0"  
2800 lbs

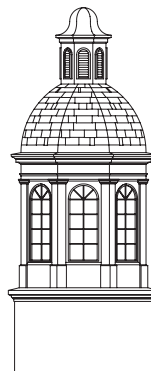

Top Cupola #1103A  
Dome Cupola #1301  
Base Cupola #705



Vented louvers (round top)  
Krinkglas windows (round top)

# **Lighthouse**

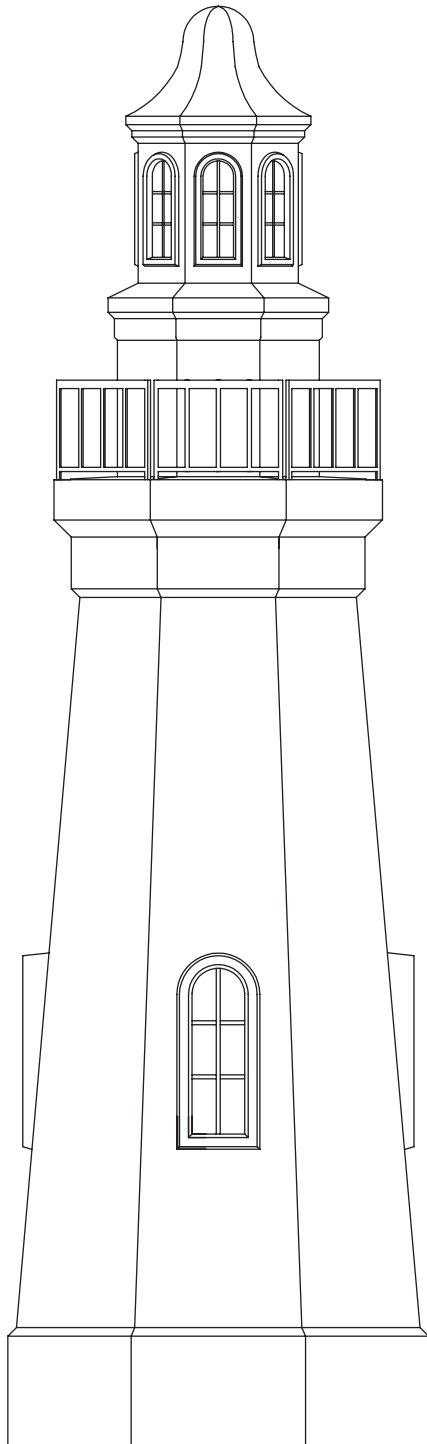

**#LH1**

Height: 29'0"

Base: 8'8"

2100 lbs

Components:

Cupola #CU-1105

Optional Picket Railing

Base Cupola #2007

*FSI's new Lighthouse is the perfect element for commercial, marina, and even religious facilities. The Lighthouse can be ground or roof mounted. Backlighting of the windows is also available.*

# ***Domes***

All prices are FOB Henderson, Texas  
Please call for freight rates

FSI manufactures both standard and custom domes. Domes up to 8' are shipped as a single unit, ready to lift and install. Domes up to 16' are shipped in two sections with assembly materials and pre-drilled bolt holes. Special finishes (including copper) are available for an additional charge. Custom domes are also available. Consult factory for pricing.

## **DOME 6**

Smooth Dome  
6' Diameter,  
3' Radius  
Weight: 175 lbs.

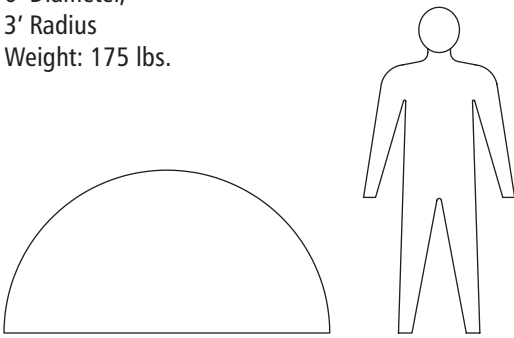

## **DOME 8**

Smooth Dome  
8' Diameter,  
4' Radius  
Weight: 305 lbs.

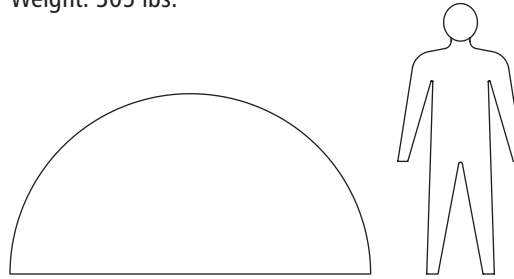

## **DOME 10**

Smooth Dome  
9'6" Diameter,  
4'9" Radius  
Weight: 475 lbs.

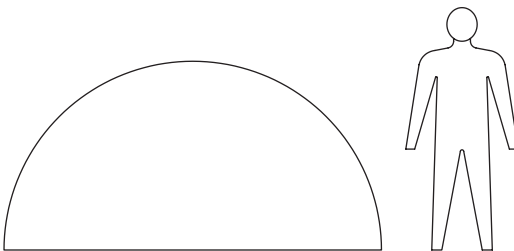

## **DOME 12**

Smooth Dome  
12' Diameter,  
6' Radius  
Weight: 1135 lbs.

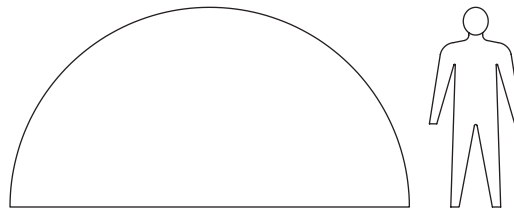

## **DOME 16 / DOME 16S**

Segmented Dome  
16' Diameter,  
8' Radius  
Weight: 1540 lbs.

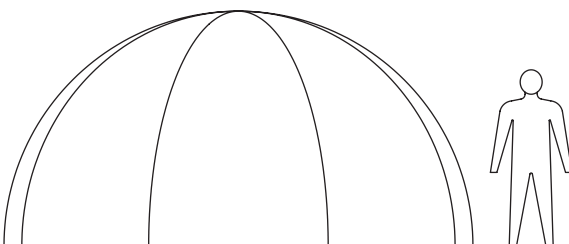

## **CUSTOM DOME**



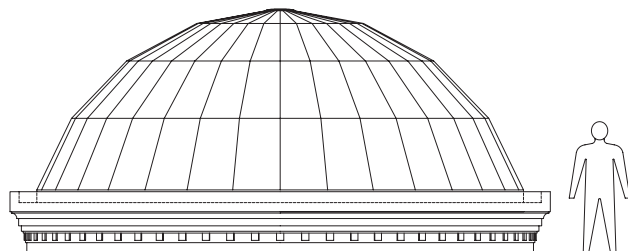





Custom  
35' Faceted  
Dome

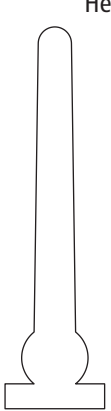
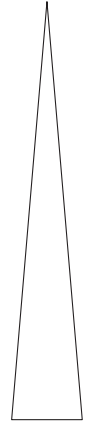
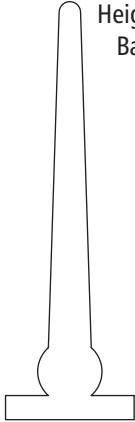

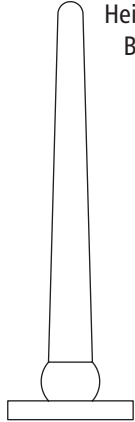
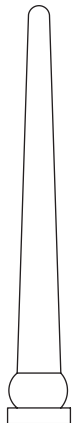
# Finials

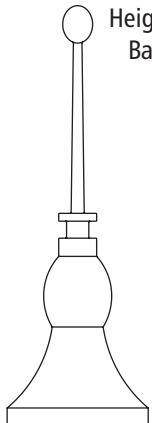
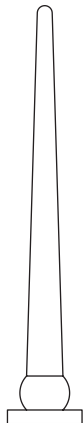
All prices are FOB Henderson, Texas  
Please call for freight rates

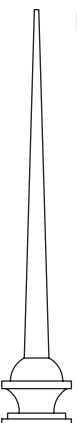
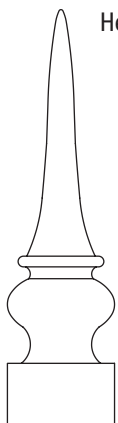
FSI has a large variety of standard finials. Many of the designs can be added to our standard cupolas. Custom finials are also available. All finials are round, some with square bases.

<p><b>FIN 01</b></p> <p>Height: 1'11" Base: 6"</p>  <p>Square Base</p>	<p><b>FIN 02</b></p> <p>Height: 3'0" Base: 6"</p>  <p>Square Base</p>	<p><b>FIN 03</b></p> <p>Height: 3'3" Base: 1'0"</p>  <p>Square Base</p>	<p><b>FIN 04</b></p> <p>Height: 4'7" Base: 6"</p>  <p>Square Base</p>	<p><b>FIN 05</b></p> <p>Height: 4'2" Base: 1'3"</p>  <p>Square Base</p>
<p><b>FIN 06</b></p> <p>Height: 5'0" Base: 9"</p>  <p>Square Base</p>	<p><b>FIN 07</b></p> <p>Height: 5'10" Base: 8"</p>  <p>Square Base</p>	<p><b>FIN 08</b></p> <p>Height: 6'4" Base: 4"</p>  <p>Square Base</p>	<p><b>FIN 09</b></p> <p>Height: 6'8" Base: 2'3"</p>  <p>Square Base</p>	<p><b>FIN 10</b></p> <p>Height: 7'0" Base: 1'3"</p>  <p>Square Base</p>
<p><b>FIN 11</b></p> <p>Height: 9'3.5" Base: 9.5"</p>  <p>Square Base</p>	<p><b>FIN 12</b></p> <p>Height: 10'0" Base: 10"</p>  <p>Square Base</p>	<p><b>FIN 13</b></p> <p>Height: 12'0" Base: 2'0"</p>  <p>Square Base</p>	<p><b>FIN 14</b></p> <p>Height: 3'3" Base: 10"</p>  <p>Square Base</p>	<p><b>MOUNTING</b></p> <p>Shown with optional "LP"</p>  <p>1'-0"</p>

NOTE: All finials, except FIN 14, available with Lightning Package. FSI standard colors and custom colors available.

# Steeple & Cupola Installation

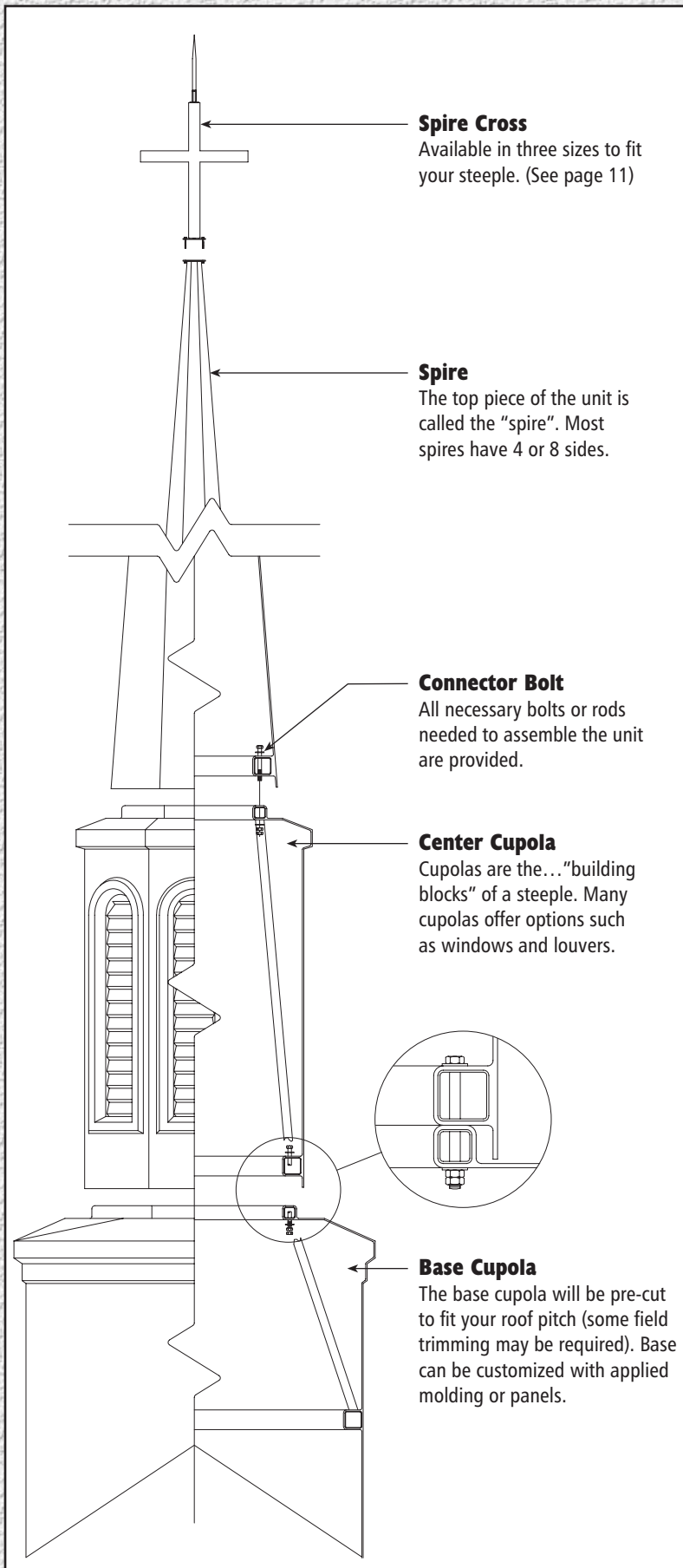

## Unloading

*When your new steeple arrives, you should plan to have adequate manpower to assist the driver in unloading. It is important to check the steeple for freight damage at this point, and report any irregularities immediately.*

## Anchor Holes

*Your steeple will arrive with tubular steel anchoring members at its base; holes for the anchor bolts are pre-drilled. Because of the many different roof pitches and types, these holes are difficult to locate precisely in advance; therefore, we recommend that your installer not attempt to locate exact anchor points until the steeple is on site.*

## Assembly

*Your new steeple will be delivered in sections (except for one-piece units). Bolts will be provided with which to assemble the various components. Your installer will need to provide the bolts that anchor the base unit to the roof.*

## Waterproofing

*Our steeples and cupolas are typically designed to be mounted above the finished roof surface, not open to the building below. Although they are designed to be leak resistant, they are not insulated; therefore, condensation can occur inside the steeple. Openings such as vented louvers can also allow moisture to enter the unit. For these reasons, we recommend waterproofing any roof openings under the steeple, including sealing around all anchor bolts.*

## Typical Anchoring Detail

Because every building is different, exact installation techniques will vary. The drawing below demonstrates one of the most commonly used anchoring methods.

The installer should verify that the steeple or cupola is firmly bolted to structural members sufficient to withstand the wind load forces imposed by the steeple. Fiberglass Specialties, Inc. can provide these loads to your building engineer or architect upon request.

All FSI steeples are designed to rest on the fiberglass panels or the steel anchoring collar.

To prevent shingle damage, the installer may wish to rest the fiberglass edge on a metal flashing. This can be easily installed by attaching it to the steeple base.

### Steel Anchoring!

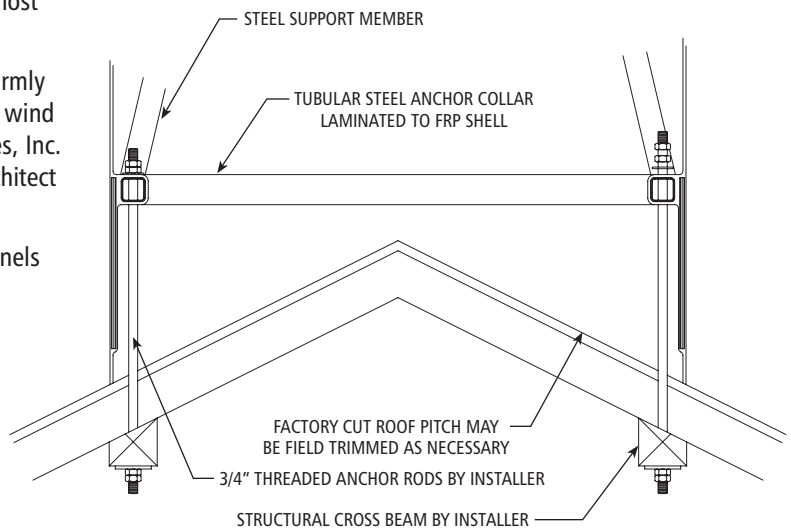

## Standing Seam Roof Installation

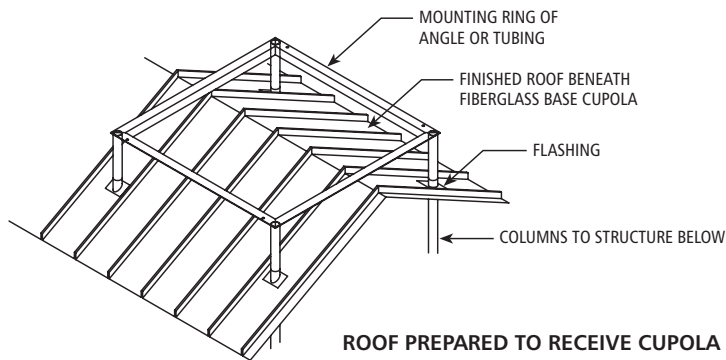

Mounting ring for top of customer's piers also available from FSI (delivered with unit). Consult factory for pricing.

## Roof Pitch Information

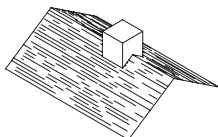

Single Ridge

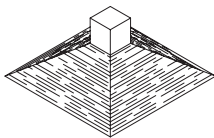

4-Way Hip Roof

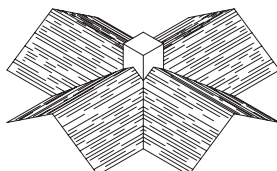

4-Way Ridge (Gable)

### HOW TO... *find your roof pitch!*

To determine the pitch of your roof, place a level against the roof as shown below. From the point where the level touches the roof, measure out 12 inches. From this point, measure the distance, in inches, down to the roof. The number out will always be 12. For example, the roof pitch here would be expressed as 6" on 12".

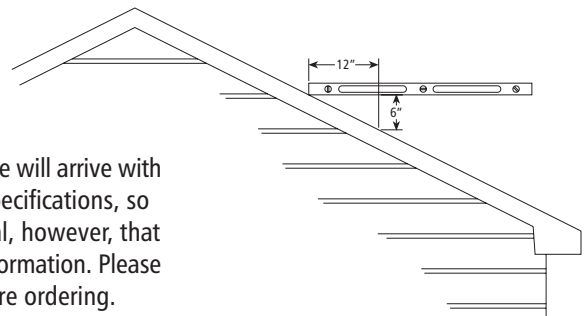

Your Fiberglass Specialties steeple will arrive with the roof pitch pre-cut to your specifications, so installation is simple! It is crucial, however, that you provide us with accurate information. Please study this section carefully before ordering.