

**FIBERGLASS SPECIALTIES, INCORPORATED**

**IMPORTANT INFORMATION !!!**

**INSTALLATION INSTRUCTIONS**

**CARE INSTRUCTIONS**

March, 2005

*"Manufacturers of Quality Architectural Fiberglass Products"*

POST OFFICE BOX 1340 " 500 AUSTIN AVENUE " HENDERSON, TEXAS 75653  
903-657-6522 " FAX: 903-657-2318 " 1-800-527-1459

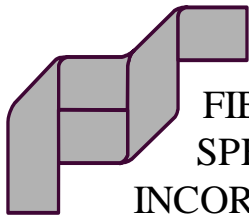

FIBERGLASS  
SPECIALTIES  
INCORPORATED

## **Before Installing Steeples, Spires, & Cupolas**

1. All components of the unit were pre-fit at the factory. There are orientation markings inside all stacked units.
2. If there is more than one component, the assembly bolts have been supplied with the shipment.
3. Installation bolts are the responsibility of the installer.
4. A roof pitch may have been cut into the base of the unit according to the information supplied to FSI. Double check the roof pitch of the building and the unit to assure they are the same before lifting
5. Inspect the roof where the unit is to be installed to assure it is watertight. In addition to water that might penetrate at the connection points, condensation inside the unit and blowing rain can also cause damage if the roof is not watertight.

**Units with Vented Louvers should have weep holes drilled in the base.**

**FSI is not responsible for any water damage.**

6. FSI units have been designed to be installed by any competent builder, installer, or contractor. All permits, compliance to local codes, capacity and suitability of supporting structures, flashing, or additional anchoring required is the responsibility of the installer. FSI will not be responsible for any crane charges, materials, labor, or the costs of any modifications to install the unit on the building.
7. FREIGHT DAMAGE – Your order was in perfect condition when it left the factory and the driver signed for it. Every attempt is made to insure the safe delivery of your order.  
If the item arrived damaged, it is the responsibility of the customer to note any damage on the freight bill and to file a freight claim with the carrier. We will assist you in this process, but only the customer can make the claim. Fiberglass Specialties, Inc. will not be responsible for filing or collection of freight claims for items damaged by the freight carrier.
8. Returned Goods – All merchandise returned to FSI without authorization will be refused. A minimum 35% restocking charge is applied to all cancelled orders.

*"Manufacturers of Quality Architectural Fiberglass Products"*

POST OFFICE BOX 1340 " 500 AUSTIN AVENUE " HENDERSON, TEXAS 75653  
903-657-6522 " FAX: 903-657-2318 " 1-800-527-1459

April, 2007

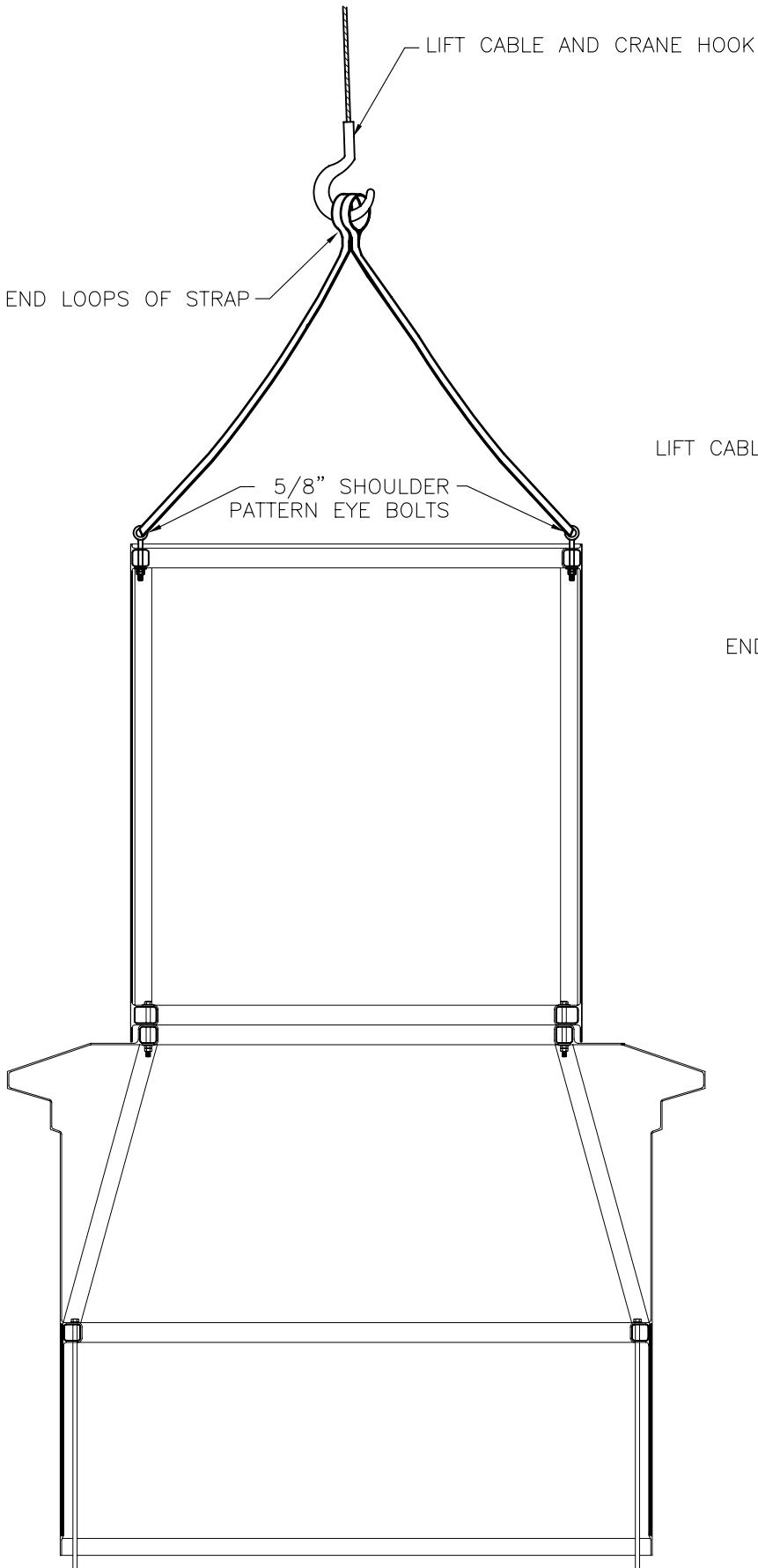

**CAUTION:**  
USE A QUALIFIED ERECTOR FAMILIAR WITH LIFTS OF THIS NATURE.

**WARNING:**  
DO NOT USE CROSS, AIR TERMINAL, OR THE THREADED RECEPTACLE THAT RECEIVES THEM AS A LIFTING POINT!!

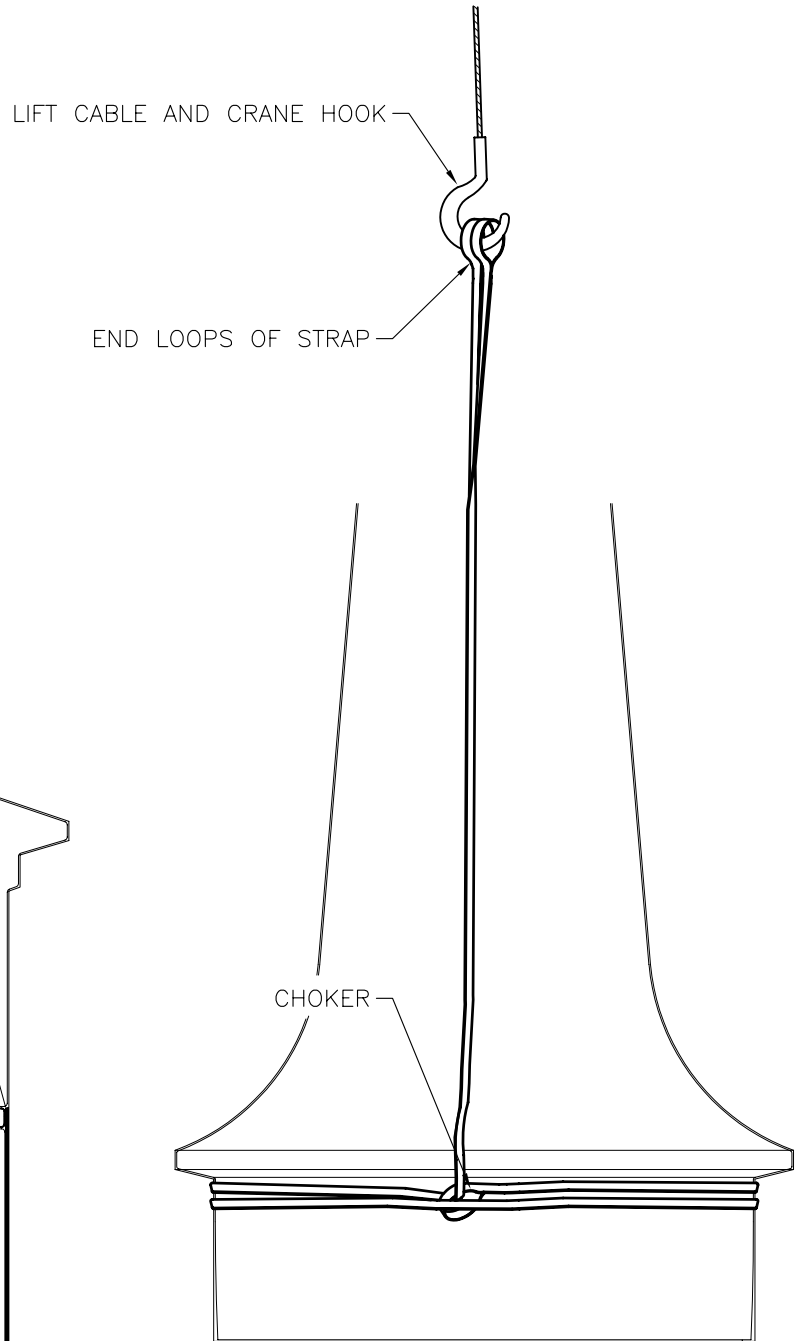

SHEET  
NO. 1 OF 1

DATE: 07-14-03	SHEET FILE NAME: LIT./LIFTING REC
DRAWN BY: TDR	REVISION: 0
CHECKED BY:	APPROVED BY:

LIFTING RECOMMENDATIONS  
FOR  
STD. STEEPLE UNITS

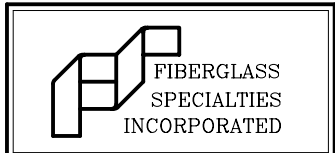

P.O. BOX 1340  
HENDERSON, TEXAS  
75653-1340  
903/657-6522  
FAX# 903/657-2318

NOTES:

1. STRAP #2 WILL BE THREADED THROUGH THE UPPER END LOOP OF STRAP #1 AND THE LOWER END LOOP OF STRAP #2, THUS CINCHING AROUND THE SPIRE. THE UPPER END LOOP OF STRAP #2 WILL THEN BE THE LIFTING POINT.
2. MAKE SURE THE LIFTING POINT IS ABOVE ANY CROSS, BALL, WEATHERVANE, OR LIGHTNING PROTECTION EQUIPMENT.
3. LIFT THE SPIRE INTO PLACE ATOP THE ROOF OR CUPOLA UNIT BELOW. BLOCKS SHOULD BE PLACED BENEATH THE EDGE OF THE SPIRE TO FACILITATE REMOVAL OF THE LIFTING STRAP.
4. INSERT AND LIGHTLY TIGHTEN THE CONNECTING HARDWARE.
5. REMOVE THE LIFTING STRAP FROM THE ANCHOR COLLAR TABS AND, USING A PRY BAR BETWEEN THE STEEL COLLARS, LIFT THE SPIRE SLIGHTLY TO REMOVE THE BLOCKING.
6. LEVEL WITH SHIMS AS REQUIRED AND TIGHTEN CONNECTING HARDWARE.

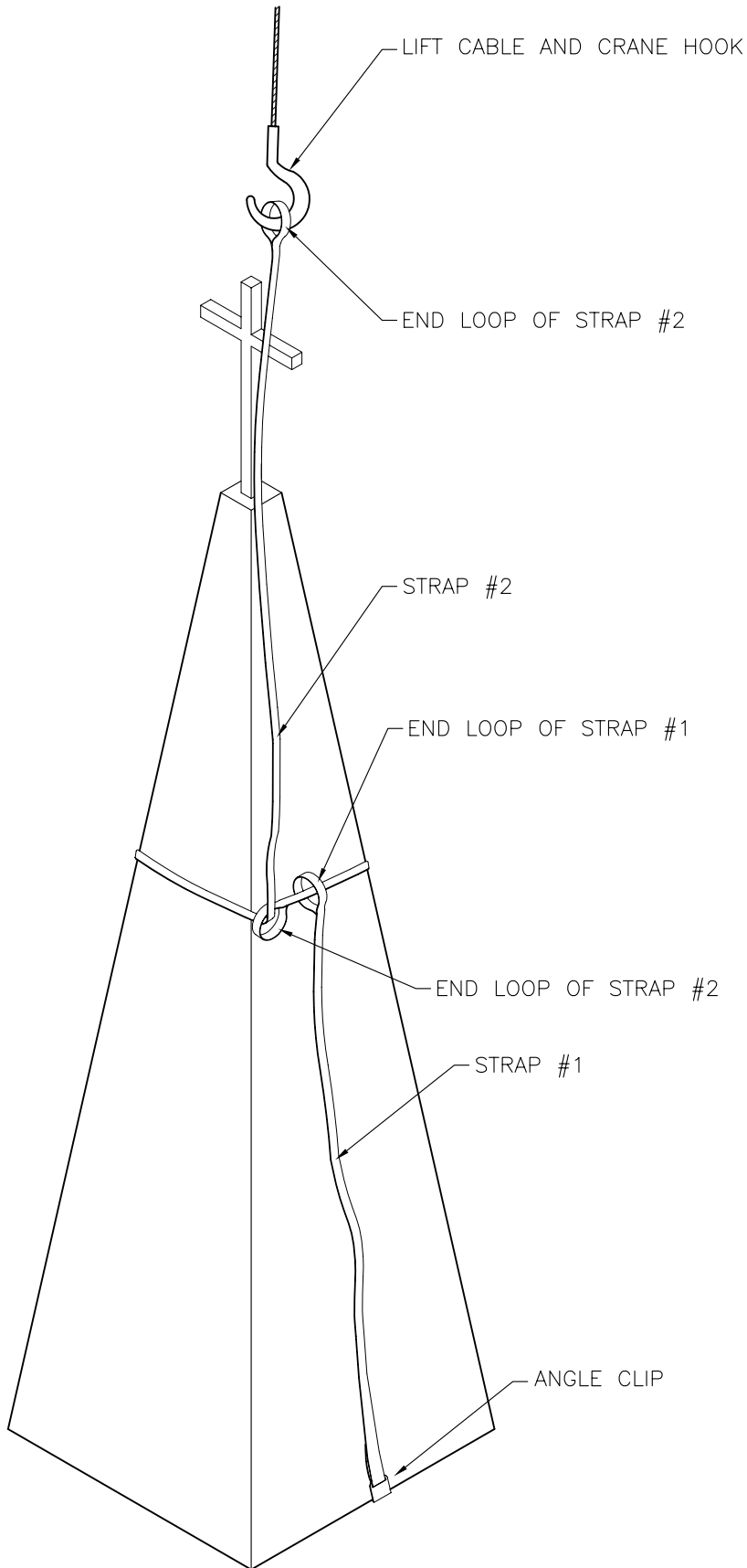

CAUTION:  
USE A QUALIFIED ERECTOR FAMILIAR WITH LIFTS OF THIS NATURE.

WARNING:  
DO NOT LIFT SPIRE BY ITS TIP!  
DO NOT USE CROSS, AIR TERMINAL, OR THE THREADED RECEPTACLE THAT RECEIVES THEM AS A LIFTING POINT!!

SHEET  
NO. 1 OF 1

DATE: 6-15-04	SHEET FILE NAME: BLOCK/NEWLIFT
DRAWN BY: TDR	REVISION: 0
CHECKED BY:	APPROVED BY:

LIFTING RECOMMENDATIONS  
FOR  
STANDARD SPIRE UNITS

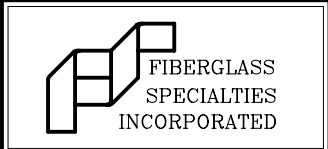

P.O. BOX 1340  
HENDERSON, TEXAS  
75653-1340  
903/657-6522  
FAX# 903/657-2318

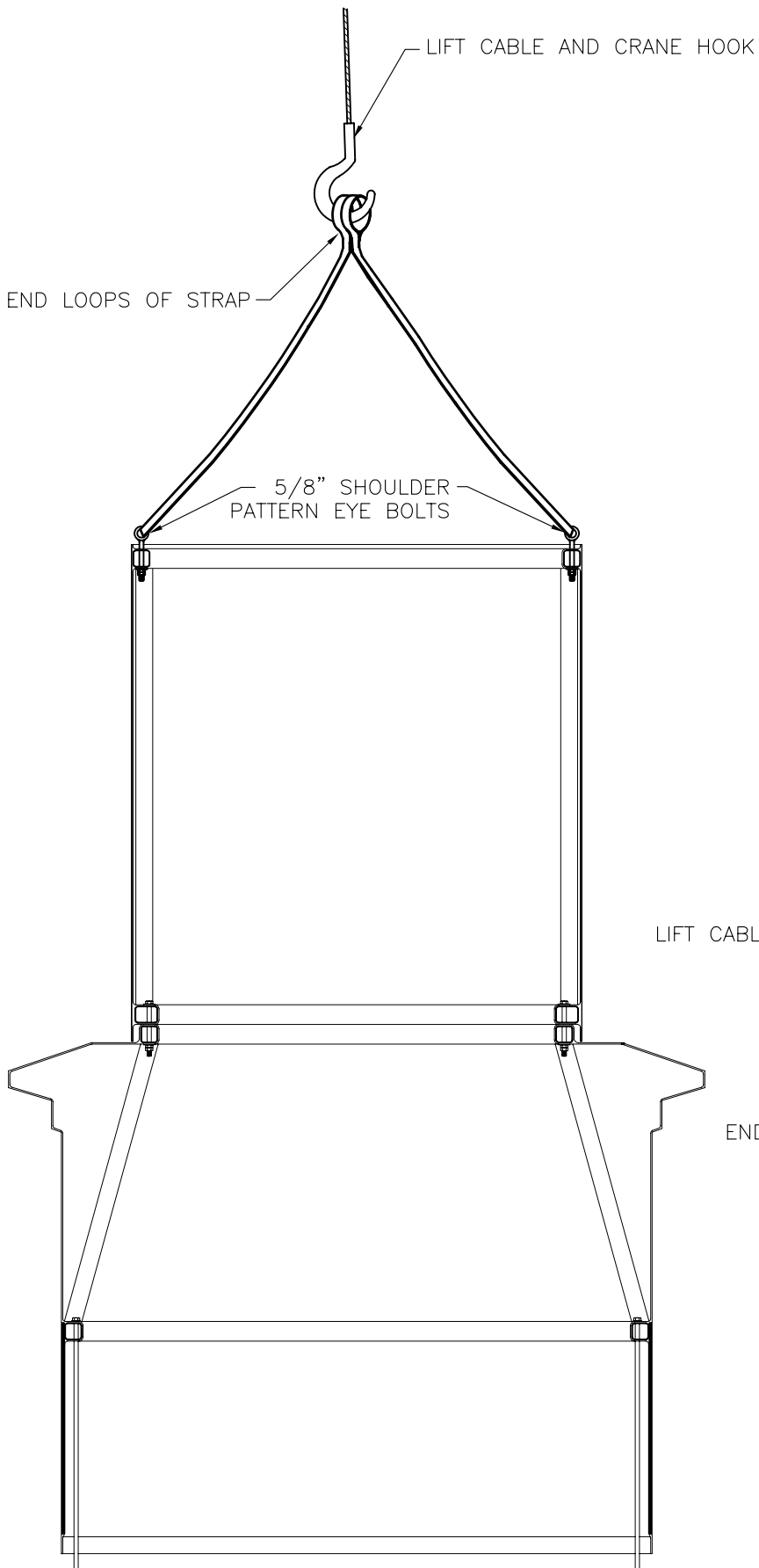

**CAUTION:**  
USE A QUALIFIED ERECTOR FAMILIAR WITH LIFTS OF THIS NATURE.

**WARNING:**  
DO NOT USE CROSS, AIR TERMINAL, OR THE THREADED RECEPTACLE THAT RECEIVES THEM AS A LIFTING POINT!!

LIFT CABLE AND CRANE HOOK

END LOOPS OF STRAP

CHOKER

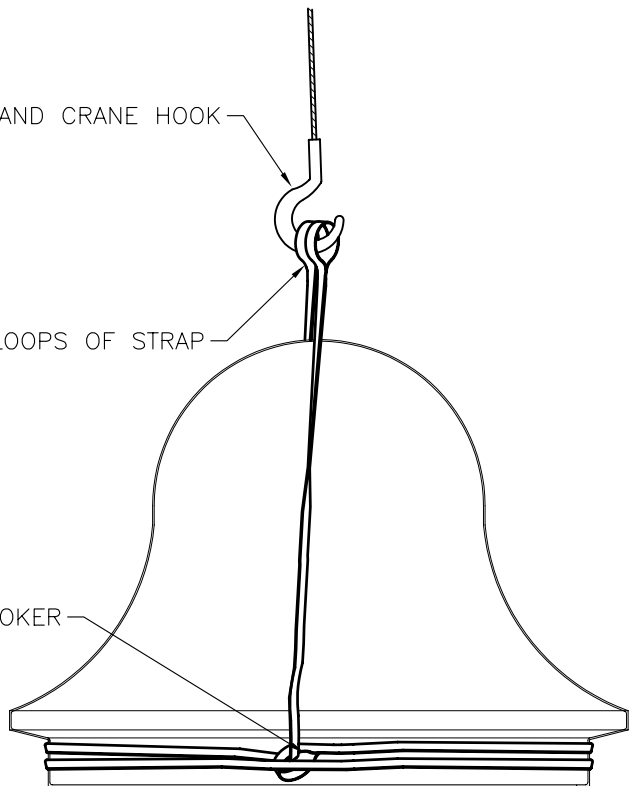

SHEET  
NO. 1 OF 1

DATE: 07-14-03	SHEET FILE NAME: LIT./LIFTING REC
DRAWN BY: TDR	REVISION: 0
CHECKED BY:	APPROVED BY:

LIFTING RECOMMENDATIONS  
FOR  
STD. CUPOLA UNITS

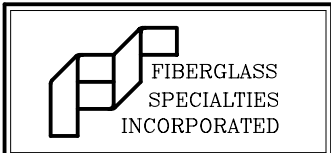

P.O. BOX 1340  
HENDERSON, TEXAS  
75653-1340  
903/657-6522  
FAX# 903/657-2318

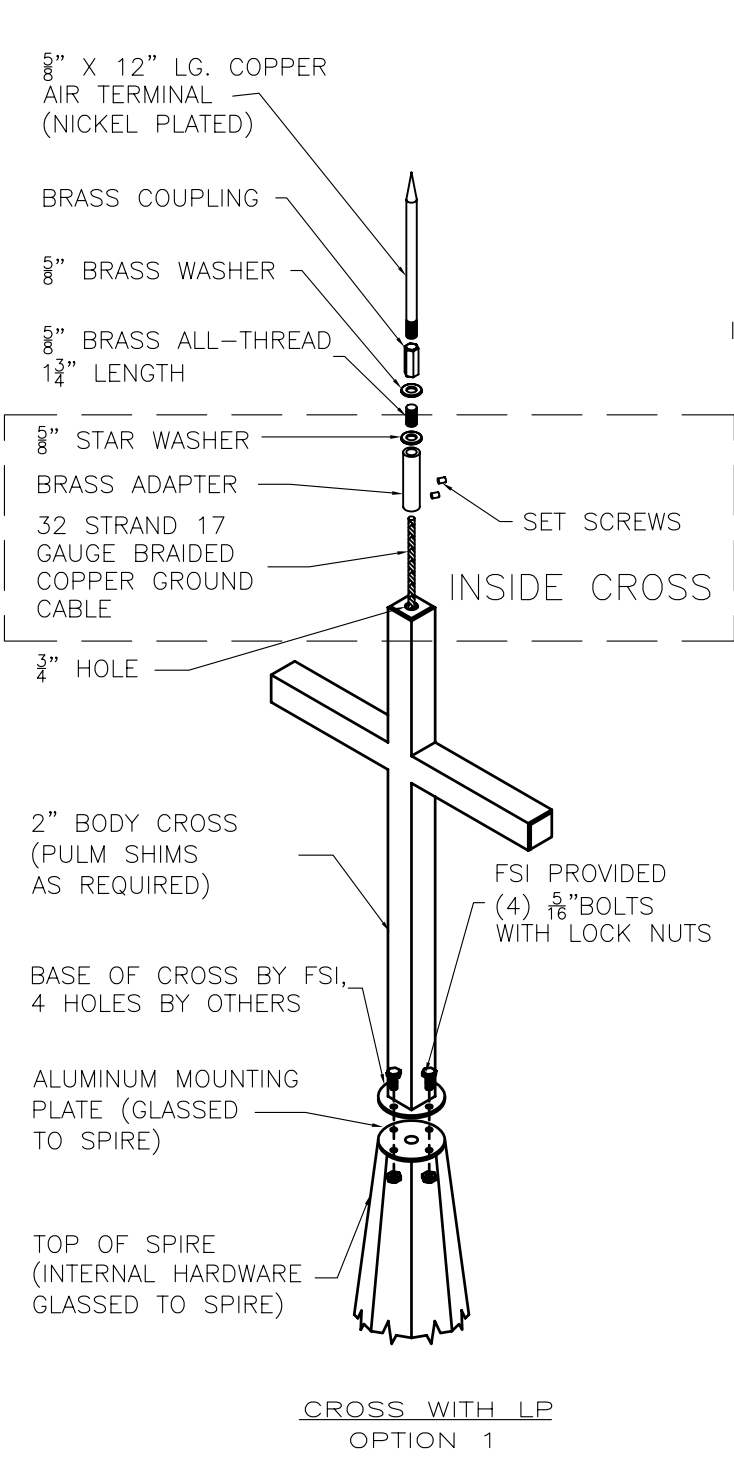

CROSS WITH LP  
OPTION 1

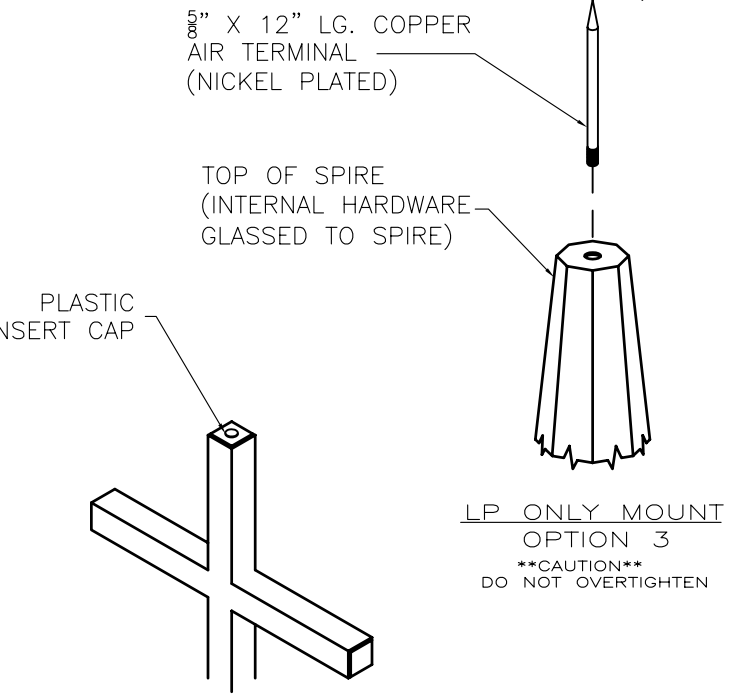

LP ONLY MOUNT  
OPTION 3  
\*\*CAUTION\*\*  
DO NOT OVERTIGHTEN

CROSS WITH NO LP  
OPTION 2

CROSS ATTACHES AS PER CROSS WITH LIGHTNING PACKAGE

NOTES:

AFTER INSTALLING AND PLUMBING THE SPIRE, PLACE AND ORIENT THE SPIRE CROSS AS DESIGNED. AT THIS POINT THE CROSS WILL NEED TO BE CLAMPED OR OTHERWISE HELD IN PLACE WHILE MARKING OR DRILLING MATCHING 5/16 HOLES IN THE CROSS MOUNTING PLATE.

ONCE THE HOLES ARE DRILLED, BOLT THE CROSS DOWN TO THE SPIRE UNITIZING THE BOLTS AND LOCK NUTS PROVIDED. WASHERS ARE PROVIDED TO BE USED AS SHIMS, BETWEEN THE PLATE. IF REQUIRED.

IF YOU ORDER THE LIGHTNING PACKAGE OPTION IN LEU OF THE CROSS, THE AIR TERMINAL WILL BE SHIPPED TAPED TO THE COPPER GROUND CABLE, INSIDE THE BOTTOM OF THE SPIRE, AND SHOULD BE INSTALLED AS FOLLOWS.

THREAD BRASS ADAPTER, ALL-THEAD AND STAR WASHER WITH GROUND CABLE ATTACHED THROUGH THE CROSS, THE ALL-THEAD SHOULD PROTRUDE THROUGH THE HOLE THE HOLE AT THE TOP OF THE CROSS. SCREW COUPLING ONTO THE 5/8\"/>

SHEET NO. 1 OF 1

DATE: 01-03-06	SHEET FILE NAME: DWG\INST\ST\NC
DRAWN BY: AGT	REVISION: 02-23-07 AJ
CHECKED BY:	SCALE: 1'=1'-0"

STANDARD SPIRE CROSS &  
LP MOUNTING DETAIL  
FOR  
FIBERGLASS SPECIALTIES, INC.  
HENDERSON TEXAS

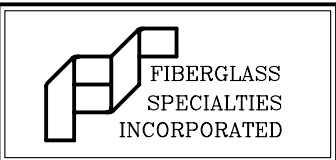

P.O. BOX 1340  
HENDERSON, TEXAS  
75653-1340  
903/657-6522  
FAX# 903/657-2318

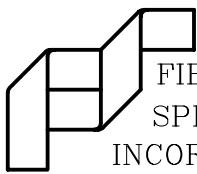

FIBERGLASS  
SPECIALTIES  
INCORPORATED

P.O. BOX 1340  
HENDERSON, TEXAS  
75653-1340  
903/657-6522  
FAX# 903/657-2318

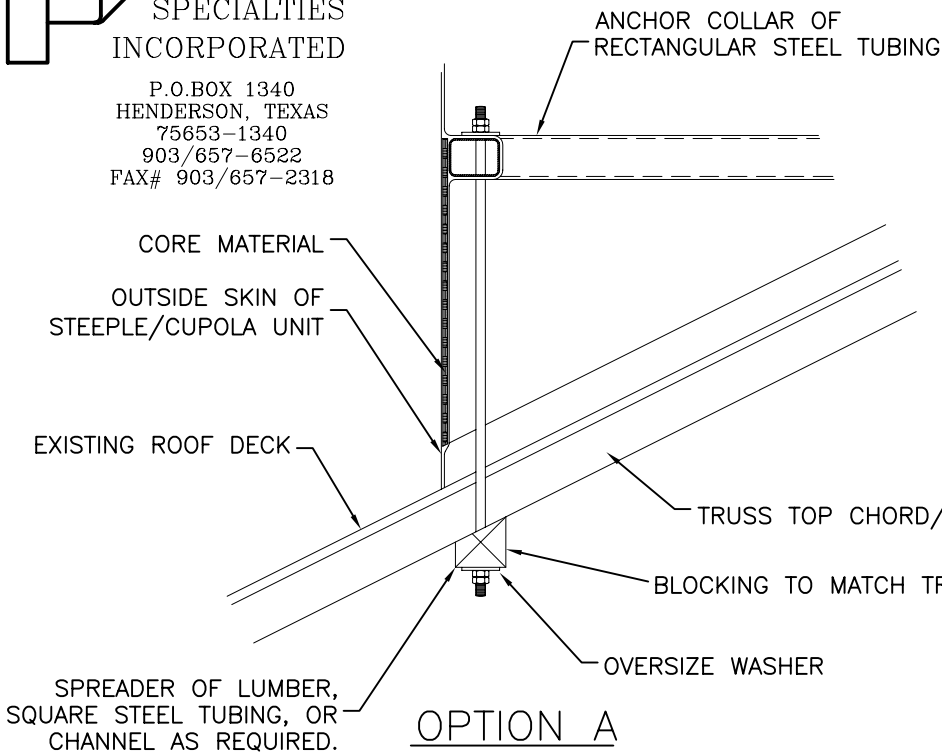

OPTION A

The lower edge of the base cupola unit is free of internal obstructions for at least 3". This edge may be cut or coped as required to match the existing roof structure. This is useful where standing seams, minor discrepancies in roof pitch, or other on site conditions requiring field fitting.

Some units have a cored side panel as shown here. It is not advisable to cut into the coring material. Where this is necessary, please contact the factory for instructions.

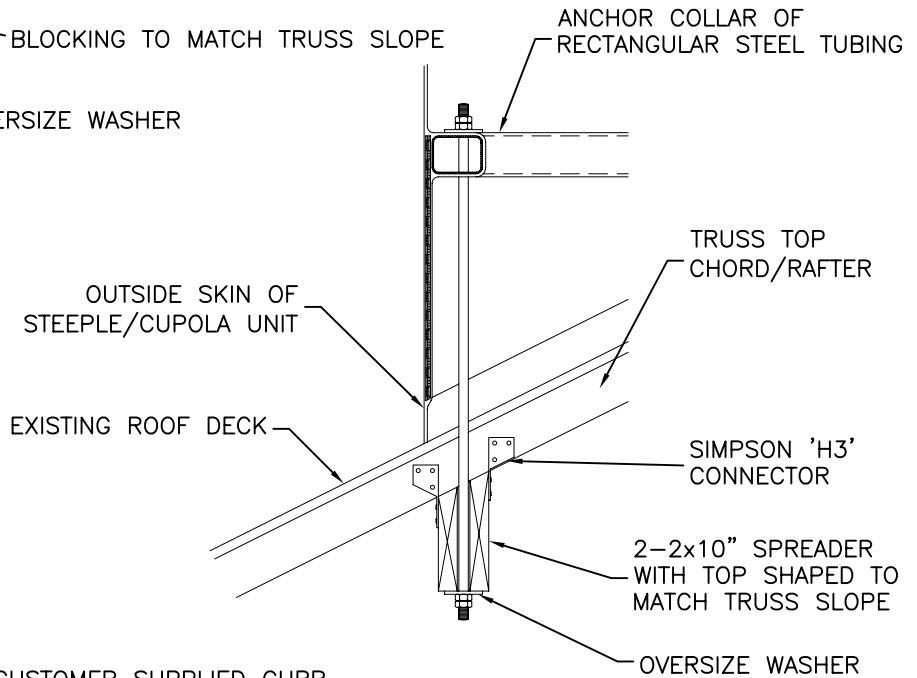

OPTION B

CUSTOMER SUPPLIED CURB OR RING OF ANGLE IRON OR STEEL TUBING, ELEVATED TO MEET ANCHOR COLLAR OF UNIT.

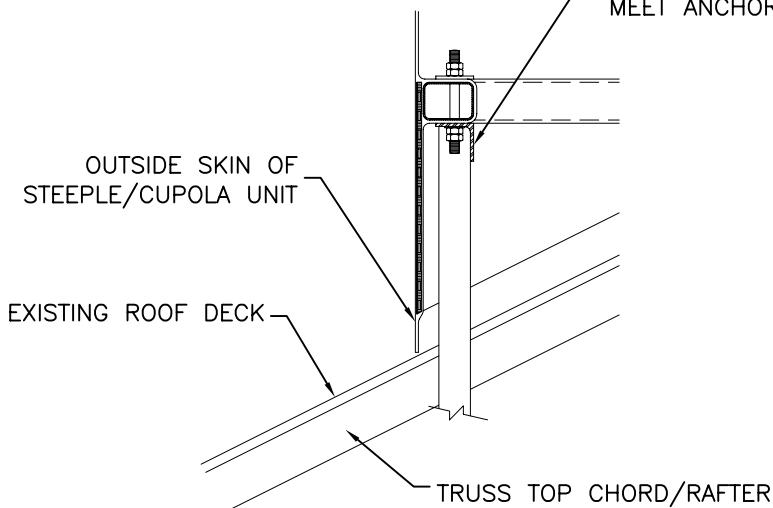

OPTION C

FIBERGLASS SPECIALTIES steeples are designed with a tubular steel anchoring ring above the bottom edge of the fiberglass shell as shown in the illustrations at left. Each unit is engineered to bear its own weight on either the bottom edge of the shell or the anchor collar. The choice of installation method is dependent upon the individual site conditions and customer preference. Customers should be aware that concentrating the loads on the thin bottom edge, especially on larger units, may damage certain types of roofing materials. Where this is a concern a raised curb or collar should be provided for mounting the unit.

Every component is pre-assembled at the factory to insure a good fit. Occasionally shims may be required between adjacent collars to achieve a level and perpendicular final product. Often these shims will be furnished by the factory and the location will be clearly marked on the appropriate collar. When the shims are not provided or variations in site conditions necessitate additional spacers, these will be the responsibility of the installer. Recommended bolting hardware is A-307 threaded rod and heavy hex nuts. Use a jam nut, lock-washer, or locknut to secure the connection. FSI recommends all bolts be checked for tightness once every six months.

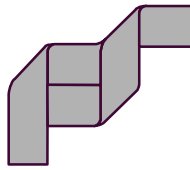

**FIBERGLASS SPECIALTIES, INCORPORATED**

## **Steeple, Spire, & Cupola** **Care Instructions**

The steeple, spire, or cupola purchased from Fiberglass Specialties, Inc. is manufactured with the latest FRP technology and is virtually maintenance free.

The following recommendations are for safety and appearance:

1. Your installer should check their connections to assure all nuts and bolts are tight. We recommend this be done 6 months after the installation and then yearly thereafter or as recommended by the installer.
2. Because your steeple, spire, or cupola is located in an exterior environment it will get dirty. We recommend cleaning the unit with a pressure washer or mild soapy water and a non-abrasive cloth. Be sure to cover the roof area where dirty water will run off from the steeple to prevent staining.
3. If you wish to reseal an area near or on the steeple we recommend white silicon sealant manufactured by GE or 3M. The white color in these sealants is approximate to the white color used on your steeple.

March, 2005

*"Manufacturers of Quality Architectural Fiberglass Products"*

POST OFFICE BOX 1340 " 500 AUSTIN AVENUE " HENDERSON, TEXAS 75653  
903-657-6522 " FAX: 903-657-2318 " 1-800-527-1459