

DESIGN PARAMETERS

The unit described in these drawings is engineered to adequately support the loads created by a wind velocity of 120 MPH at a height of 50' above ground using ASCE 7-95 exposure category "C". An additional 2' in height was added to the base during these calculations to account for variations in roof pitch, etc.

P.O. BOX 1340
HENDERSON, TX 75653-1340
903/657-6522
FAX# 903/657-2318

FIBERGLASS
SPECIALTIES
INCORPORATED

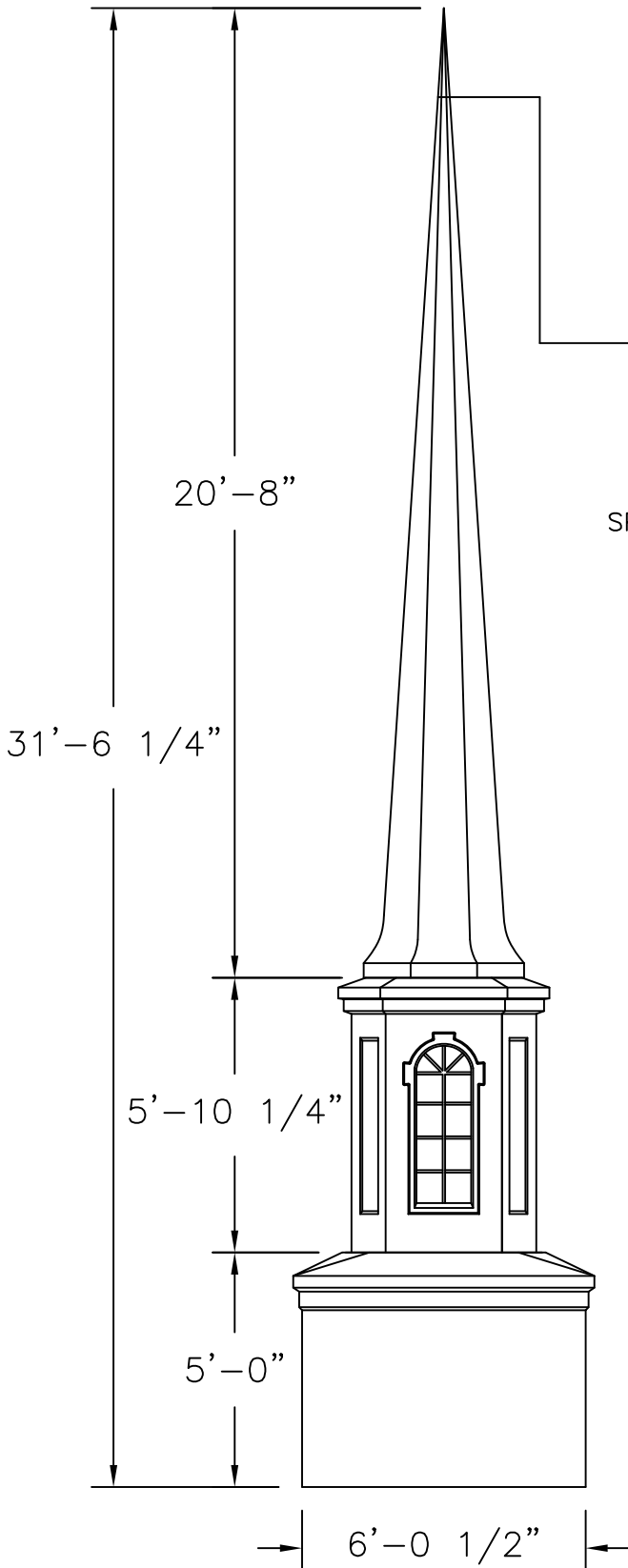

OPTIONAL LIGHTNING PROTECTION AIR TERMINAL

OPTIONAL 4' SPIRE CROSS (ALSO AVAILABLE IN 2' AND 3' HEIGHTS).

OPTIONAL 9" DIAMETER BALL (ALSO AVAILABLE IN 6" DIAMETER)

ALL UNITS WERE ENGINEERED WITH A 4' CROSS AND 9"Ø BALL INSTALLED PER FIBERGLASS SPECIALTIES, INC. STANDARD MOUNTING PROCEDURES.

SPIRE UNIT #621

CUPOLA UNIT #605 WITH KRINKLGLAS WINDOWS (ALSO AVAILABLE WITH VENTED LOUVERS)

BASE CUPOLA UNIT #607

1 ELEVATION
E1

THESE DRAWINGS ARE THE PROPERTY OF FIBERGLASS SPECIALTIES INC. DIMENSIONS AND DETAILS ARE SUBJECT TO CHANGE WITHOUT NOTICE. ALL CUPOLA AND STEEPLE UNITS ARE FABRICATED USING MINIMAL STANDING SEAMS UNLESS OTHERWISE NOTED. ALL CUPOLA AND STEEPLE UNITS ARE DESIGNED TO BE ERECTED ON A COMPLETED ROOFING SYSTEM AND ARE NOT GUARANTEED TO BE LEAK PROOF.

Project: STEEPLE UNIT #13

Date: 11-06-00

Revisions 12-14-05 AGT

Scale: 1/4" = 1'

Drawing By: RLB

Checked By: ALL-STL

File # ST13F

Sheet #

E1F

ELEVATION